

**SANITARY COMPRESSED AIR**

# **COMPRESSORS**

**with membrane dryer**

**with thermal protection**

**with hour meter**

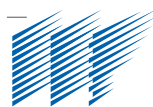

**METASYS**

# METASYS Compressors

## Reliable solutions for the dental office

### Highest medical standard

Compressed air used in dental practices must comply with highest sanitary and medical standards. This is why all METASYS META Air compressors work absolutely oil-free and are equipped with an integrated filter and dryer system (except Light models).

#### > Light versus Standard version

Almost all compressors are available in standard and light version

	Light version	Standard version
Prefilter	✓	✓
Microfilter	-	✓
Dryer	-	✓



### Quality in all details



#### > Filtration system

Double filtration system with a rating of 0.01 µm

#### > Membrane dryer

Powerful drying system for absolutely dry air

#### > Compressor technology

Low noise operation and maximum pressure up to 10 bar (META CAM)

#### > Air tank

Antibacterial inner tank powder coating to prevent corrosion

#### > Operating hours meter

To ensure the exact definition of maintenance intervals

#### > Thermal protection

Double, amperometric and temperature control for optimal safety

# METASYS Compressors

## For a smooth running practice

### Effective conservation of value for compressed air operated instruments and equipment

Moisture in the dental compressed air impairs the adhesion - e.g. of composite material - and therefore their durability. In addition, the moist environment offers optimum habitat for microorganisms. Dry compressed air, on the other hand, prevents the formation of biofilm in the tubes as well as corrosion on the compressor and operated instruments.

METASYS META Air compressors are equipped with an extremely powerful membrane filter system. Moisture in the dental compressed air is therefore effectively prevented, even under the most difficult climate conditions. METASYS membrane dryers are maintenance-free.



### Best treatment results through hygienic compressed air



Oil-operated compressors are not suitable for use in dental practices: Even the smallest traces of oil in the compressed air pose a negative influence on the durability of filling material on the tooth substance. At the same time, lubricating oil causes deposits in the air supply lines. They cause loss of power and premature wear and tear of compressors and compressed air operated instruments.

META Air compressors work absolutely free of oil and therefore ensure optimum, long-term treatment results.

### Optimum sanitary conditions for the protection of patient and treatment team

During the dental treatment, compressed air comes in contact with open wounds. At the same time, the use of compressed air causes an aerosol cloud, which poses a significant risk of infection for the dental staff and patients. A hygienic preparation of dental compressed air is therefore imperative.

METASYS META Air compressors are equipped with a double filtration system with a rating of 0,01  $\mu\text{m}$ .\* It ensures odour-free compressed air and optimum protection from infection. To assure continuous sanitary conditions, the filters are replaced during maintenance.



\* METASYS compressors meet the requirements of classes 1/4/1 in accordance with the compressed air requirements of ISO 8573\_1:2010.

# METASYS Compressors

## Highest quality in all details

### Patented intake system

The intake air stream is channelled through a labyrinth of compressor components. This cools down the motor and the components and lowers the suction noise level.

In addition, numerous specially designed cooling fins on the outside of the unit allow for optimised heat dissipation.

### High-quality components for the toughest applications

The use of high-tech components in the electrical motors brings about a high degree of efficiency and a consistent operational motor performance. Heat-resistant ball bearings allow for smooth operation and increase the service life of the entire unit.

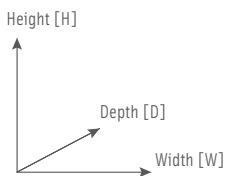
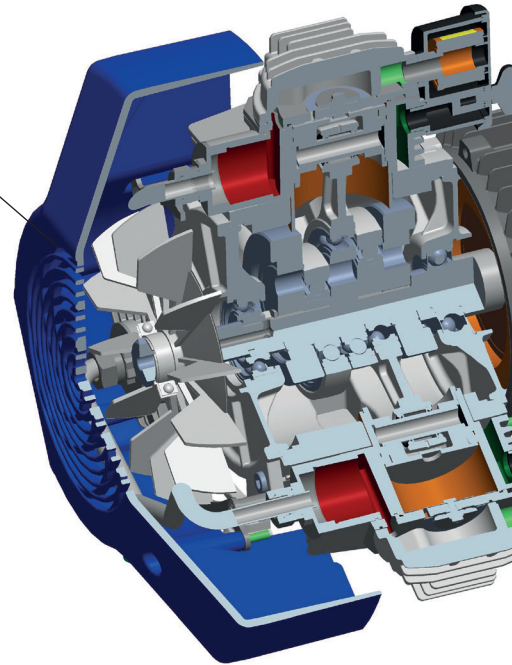

	<b>META Air 24s Light</b>	<b>META Air 24 Light</b>	<b>META Air 30</b>	<b>META Air 30 Light</b>
Item no.	03020201	03020203	03020207	03020205
Power supply	230 V	230 V	230 V	230 V
Frequency	50 Hz*	50 Hz*	50 Hz*	50 Hz*
Electric motor power	0,55 kW	1,1 kW	1,1 kW	1,1 kW
Delivery rate (5 bar)	77 l/min	135 l/min	120 l/min	135 l/min
Operating time	≤ 50 %	≤ 50 %	≤ 50 %	≤ 50 %
Tank capacity	24 l	24 l	40 l	40 l
Pressure range	5-7 bar	5-7 bar	5-7 bar	5-7 bar
Sound level	65 dB(A)	65 dB(A)	65 dB(A)	65 dB(A)
Sound level with cover	52 dB(A)	52 dB(A)	-	-
Dimensions (H x W x D)	550 x 400 x 400 mm	600 x 430 x 400 mm	770 x 710 x 410 mm	770 x 600 x 410 mm
Dimensions with cover (H x W x D)	800 x 530 x 500 mm	800 x 530 x 500 mm	-	-
Weight	28 kg	29 kg	38 kg	42 kg
Weight with cover	44 kg	45 kg	-	-
Order no with cover	40030006	40030006	on request	-

Order no of service kits (1500/3000 h) and filter cartridge replacement kits are available upon request.

# METASYS Compressors

## The highest level of technology

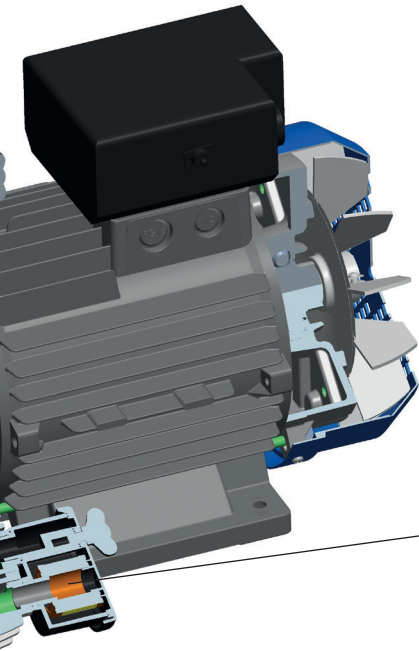

The aggregate is the core of any compressor. The perfect interplay of electrical motor and compression technology guarantees the highest level of performance in everyday use. The use of high-quality components guarantees the highest level of reliability in the toughest applications. METASYS compressors meet these customer requirements in any given situation.

### Optimised compression process

The latest generation of META Air compressors will convince with a new technical feature: Each cylinder is equipped with its own air filter. This improves the intake air filtration process meaning there is sufficient air volume for compression at all times. This optimised compression process increases the service life of the pistons and valves.

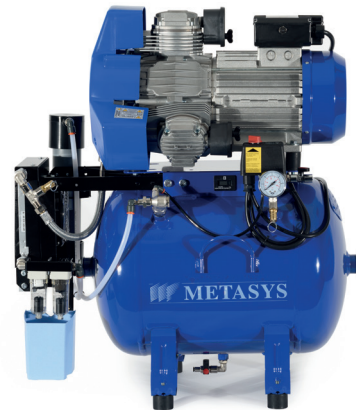
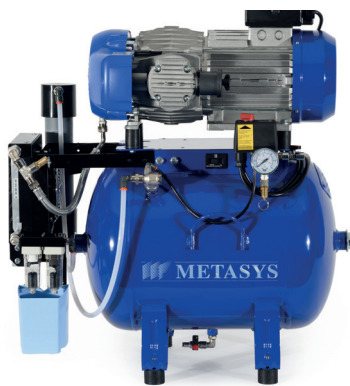

#### META Air 150

03020004

230 V

50 Hz\*

1,5 kW

152 l/min

≤ 70 %

40 l

5-7 bar

66 dB(A)

53 dB(A)

770 x 710 x 410 mm

890 x 720 x 490 mm

50 kg

98 kg

03020104

#### META Air 150 Light

03020003

230 V

50 Hz\*

1,5 kW

170 l/min

≤ 80 %

40 l

5-7 bar

66 dB(A)

53 dB(A)

770 x 600 x 410 mm

890 x 720 x 490 mm

46 kg

94 kg

3020103

#### META Air 250

03020006 | 03020026

230 V | 400 V

50 Hz\*

2,2 kW

225 l/min

≤ 70 %

40 l

5-7 bar

66 dB(A)

53 dB(A)

810 x 710 x 410 mm

890 x 490 x 720 mm

58 kg

106 kg

03020106 | 03020126

#### META Air 250 Light

03020005 | 03020025

230 V | 400 V

50 Hz\*

2,2 kW

250 l/min

≤ 80 %

40 l

5-7 bar

66 dB(A)

53 dB(A)

810 x 600 x 410 mm

890 x 490 x 720 mm

54 kg

102 kg

03020105 | -

# METASYS Compressors

## Powerful solutions for large practices and dental clinics

Due to the increased air volume requirement, large practices and dental laboratories require powerful compressors with a high compressed air output. The tank capacity of these high-performance compressors has been calculated accordingly and also allows you to work without any interruptions.

The META Air 450, 650, 900 and 1300 Light compressors by METASYS meet these requirements to the highest degree.

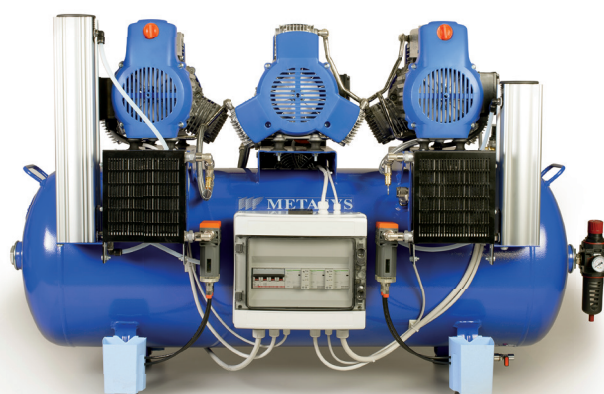
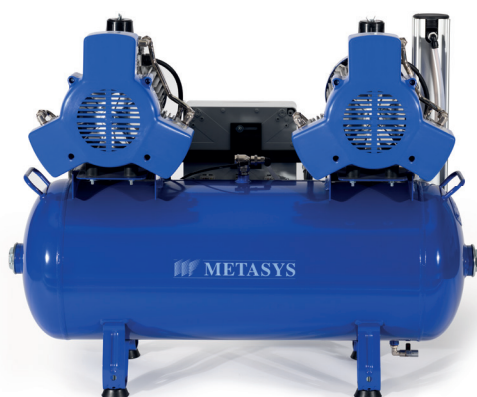

	<b>META Air 450</b>	<b>META Air 450 Light</b>	<b>META Air 650</b>	<b>META Air 650 Light</b>
Item no.	03020008	03020007	03020010	03020009
Power supply	400 V	400 V	400 V	400 V
Frequency	50 Hz*	50 Hz*	50 Hz*	50 Hz*
Electric motor power	4,4 kW	4,4 kW	6,6 kW	6,6 kW
Delivery rate (5 bar)	450 l/min	500 l/min	660 l/min	750 l/min
Operating time	≤ 70 %	≤ 80 %	≤ 70 %	≤ 80 %
Tank capacity	90 l	90 l	200 l	200 l
Pressure range	5-7 bar	5-7 bar	5-7 bar	5-7 bar
Sound level	69 dB(A)	69 dB(A)	72 dB(A)	72 dB(A)
Sound level with cover	56 db(A)	56 dB(A)	-	-
Dimensions (H x W x D)	820 x 1100 x 630 mm	820 x 1100 x 600 mm	900 x 1450 x 820 mm	910 x 1100 x 600 mm
Dimensions with cover (H x W x D)	1020 x 1245 x 725 mm	1020 x 1245 x 725 mm	-	-
Weight	118 kg	113 kg	183 kg	173 kg
Weight with cover	220 kg	215 kg	-	-
Order no with cover	03020108	03020107	-	-

	<b>META Air 900</b>	<b>META Air 900 Light</b>	<b>META Air 1300 Light</b>
Item no.	03020041	03020042	03020043
Power supply	400 V	400 V	400 V
Frequency	50 Hz*	50 Hz*	50 Hz*
Electric motor power	10 kW	10 kW	15 kW
Delivery rate (5 bar)	780 l/min	900 l/min	1350 l/min
Operating time	≤ 70 %	≤ 80 %	≤ 80 %
Tank capacity	270 l	270 l	500 l
Pressure range	5-7 bar	5-7 bar	5-7 bar
Sound level	75 dB(A)	75 dB(A)	78 dB(A)
Dimensions (H x W x D)	1030 x 1560 x 1000 mm	1030 x 1560 x 1000 mm	1050 x 1980 x 780 mm
Weight	240 kg	220 kg	330 kg

Order no of service kits (1500/3000 h) and filter cartridge replacement kits are available upon request.

\* also available with 60 Hz

# META CAM

## Compressors for CAD/CAM milling systems

Conventional dental compressors within the standard pressure range of 5 to 7 bar are unable to satisfy the requirements of many dental milling machines. However, CAD/CAM milling systems require an operating pressure of up to 10 bar, in order to guarantee safety with a tool change for example. META CAM compressors have been designed specially for such systems, because they guarantee a pressure range of 8 to 10 bar in continuous operation. Equipped with membrane drying and a double filtering process, they ensure the supply of oil-free, dry and perfectly hygienic compressed air, which is decisive for the quality of the end products. The right compressor for many of the CAD/CAM systems available on the market can be found on the basis of the respective requirements profile (performance and output) of the milling system. All META CAM compressors are also available with a cover, to ensure quiet operation. In this way it is possible to reduce the noise level to 54 dB(A).

### The right choice

We are happy to assist you in choosing the right META CAM compressor for your specific milling or grinding machine. You can find further information at [www.metasys.com](http://www.metasys.com).

### High pressure range up to 10 bar

META CAM compressors operate within a pressure range of 7 to 10 bar.

### High quality components in the units

META CAM units are equipped with specific components, in order to counter the loads within the high pressure range.

### Optional sound proofing cover

The majority of META CAM compressors are optionally available with a sound proofing cover.

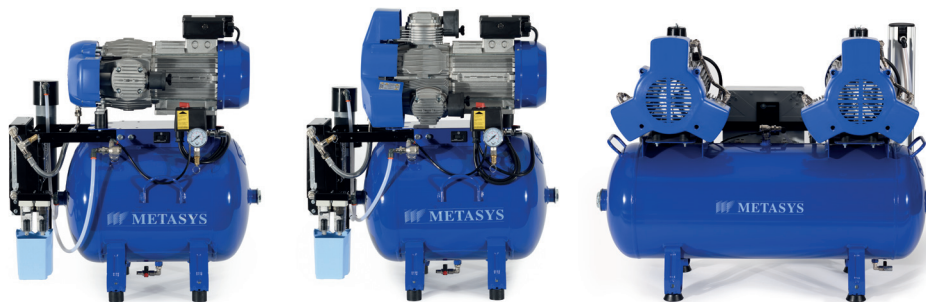

	META CAM 150	META CAM 250	META CAM 450	META CAM 650
Item no.	03030004	03030006   03030026	03030008	on request
Power supply	230 V	230 V   400 V	400 V	400 V
Frequency	50 Hz*	50 Hz*	50 Hz*	50 Hz*
Electric motor power	1,5 kW	2,2 kW	4,4 kW	6,6 kW
Delivery rate (5 bar)	152 l/min	225 l/min	450 l/min	
Delivery rate (8 bar)	103 l/min	148 l/min	296 l/min	440 l/min
Operating time	≤ 50 %	≤ 50 %	≤ 50 %	≤ 50 %
Tank capacity	40 l	40 l	90 l	200 l
Pressure range	8 - 10 bar	8 - 10 bar	8 - 10 bar	8 - 10 bar
Sound level	66 dB(A)	66 dB(A)	69 dB(A)	73 dB(A)
Sound level with cover	<b>53 dB(A)</b>	<b>53 dB(A)</b>	<b>56 dB(A)</b>	-
Dimensions (H x W x D)	770 x 710 x 410 mm	810 x 710 x 410 mm	820 x 1100 x 630 mm	850 x 1400 x 920 mm
Dimensions with cover (H x W x D)	890 x 720 x 490 mm	890 x 720 x 490 mm	1020 x 1245 x 725 mm	-
Weight	50 kg	58 kg	118 kg	193 kg
Weight with cover	98 kg	106 kg	220 kg	-
Item no. with cover	03030104	03030106   03030126	03030108	-

\* also available with 60 Hz

A compressed air requirement assessment must be carried out prior to selecting a META CAM compressor or the selection must be validated in conjunction with the milling machine following installation.

## Guarantee period

The guarantee period for compressors is 12 months. If the required yearly maintenance, the "1500 hours" or the "3000 hours" maintenance are performed, the guarantee period can be extended by 1 year, although by no more than 2 years in all. The maximum possible guarantee period is therefore 3 years.

## Maintenance intervals

Compulsory maintenance rates have to be met precisely. The following maintenance and inspections have to be done: yearly filter cartridge - exchange ("Filter cartridge - exchange kit"), the 3000 or 1500 hours maintenance, depending on compressor versions, with the "3000 hours kit + valve block (complete)" or the "1500 hours kit 24/30 + valve block (complete)". The required inspections have to be registered inside the METASYS manual. METASYS reserves to himself the right to request those registrations to ascertain maintenance and inspection rates.



### Maintenance kits

on inquiry, also by email: [info@metasys.com](mailto:info@metasys.com)

Please provide the module number and serial number of the compressor to be serviced.

### 3000 hours kit + valve block (complete)

META Air (from META Air 70), META Air Light (from META Air 70 Light), META CAM models

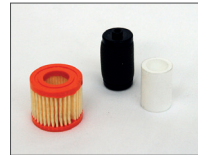

### 1500 hours kit 24/30 + valve block (complete)

META Air 24/30

### Filter cartridge - exchange kit

all META Air, META Air Light, META CAM models

## Accessories



### METASYS covers

Different covers to minimise noise can be ordered for the relevant META Air / META CAM versions.



### Digital Manometer

Item no. 40400005

The digital manometer is a measuring device for negative pressure and compressed air. The measurable pressure lies between -1 and 30 bar. It enables the exact determination of suction vacuum, air and water pressure of dental units.

## METASYS - your strong partner



- Amalgam separation
- Hygienic compressed air
- Suction
- Water decontamination
- Infection control
- Recycling

### METASYS Medizintechnik GmbH

Florianistraße 3, 6063 Rum bei Innsbruck, Austria

☎ +43 512 205420 | 📠 +43 512 205420 7

[www.metasys.com](http://www.metasys.com) | [info@metasys.com](mailto:info@metasys.com)



#### GERMANY

+49 8823 938 44 33

[info@metasys.com](mailto:info@metasys.com)

#### FRANCE

+33 4 37 90 22 15

[info@metasys.fr](mailto:info@metasys.fr)

#### ITALY

+39 045 981 4477

[desitalia@metasys.com](mailto:desitalia@metasys.com)